

OPERATING EXPERIENCES FROM 18 MICROTURBINE APPLICATIONS FOR CHP AND INDUSTRIAL PURPOSES

Jan-Erik Hanssen, EU, Bruxelles, Belgium
Arto Riikonen, Gasum Oy, Finland
Corfitz Noren, Swedish Gas Technology Centre, Sweden
Gerth Karlsson, Vattenfall AB, Sweden
Lars Malmrup/Stefan Ernebrandt, Turbec AB, Sweden
Roar Stokholm/ Bjørn Jarle Veland, Statoil A/S, Norway.
Felicia Fock/Hakon Mosbech, Energi E2 A/S, Denmark
Jan de Wit, Danish Gas Technology Centre, Denmark
Aksel Hauge Pedersen, DONG A/S, Denmark (presenter)

ABSTRACT

The experiences gathered in this project are related to a demo project named OMES (Optimised Microturbine [Energy](#) Systems), which partly has been financed through the EU 5th Frame Working Programme. Participants in the project has been the above mentioned organisations. The project was running from September 2001 through April 2004, and tested/demonstrated a 100 kW micro turbine at a variety of applications, like:

Flexible steam generation, CO₂ fertilization in greenhouses, cooling, traditional CHP (Schools, Business Centres, etc.) and Cluster installation of microturbine CHP units. The demo sites were placed in Finland, Swden, Norway, Denmark, Germany and Ireland.

The project showed that the technology is reliable and working satisfactory. Still work must be done to reduce costs before the micro turbine will get a fully commercial break through.

The original goals for power efficiency and overall efficiency were to achieve ≥ 30 % power efficiency during full load operation and overall efficiency ≥ 80 % (ref. LCV).

The goal for power efficiency was meet at full load, still the overall efficiency stayed slight below the 80%. The latter was primarily due to higher water inlet temperatures than originally planned for, at many of the demonstration plants. An inlet water temperature less than 50 °C seems necessary to achieve the target of 80 % total efficiency. The original environmental goals for the OMES project were focusing NO_x and the measurements showed NO_x values at target level of 15 ppm at 15 % O₂.

SUMMARY

The OMES Project [1], running from September 2001 through April 2004, has partly been financed through the EU 5th Frame Working Programme. Participants in the project were Gassum, Finland, Vattenfall/SGC and the microturbine manufacturer Turbec from Sweden, Statoil, Norway, and DONG and Energi E2 from Denmark. DONG was overall project leader, assisted by the Danish Gas Technology Centre (DGC).

The installations, spread over six countries (Finland, Sweden, Norway, Denmark, Germany and Ireland), are a mix of industrial, commercial and domestic installations. The installations cover a number of different applications and fuels:

- Traditional small scale CHP (schools, business centres, etc.)
- Flexible steam generation
- CO₂ fertilization in greenhouses
- Cooling
- Cluster installation of microturbine CHP units
- Natural gas, biogas and methanol

Data on energy efficiency, availability, emission, O/M costs etc., covering more than 100.000 running hours, are recorded and reported over the operation period from 2002, when most of the installations were made, to April 2004.

Table 1. Overview of Installations in the OMES Project

Country	Units	Demo host	Type of installation
DK	5	Diff. apartment houses, Køge	CHP - Cluster
DK	2	Copenhagen Airport	CHP - Boiler house
DK	1	M/R station, Lyngø	CHP - M/R station
N	1	Statoil, Stavanger	CHP- Cooling, methanol
N	1	Fjell Borettslag	CHP - Methanol
S	1	Mariestads Avl. Rening.	CHP - Biogas (sewage)
S	1	Klitte & Lundh (Green House)	CHP - CO ₂ enrichment
S	1	School in Kävlinge	CHP - Boiler house
SF	1	VTT, Helsinki	CHP - cooling
D	1	Business Centre, Hamburg	CHP - heating
EI	1	Irish Co-Op Society, Limerick	CHP - steam
EI	1	St. John of God Hosp. Dublin	CHP - Hospital
EI	1	SAS Radisson Limerick	CHP - Hotel

The major results observed during the project were related to:

- Heat and power efficiency
- Environmental conditions
- Installation - and operation and maintenance costs
- Daily operation conditions

Result overview can be seen on page 19-20

Table 2. Success Criteria and obtained results

Success Criteria for the OMES project	Remarks
Power efficiency $\geq 30\%$ during full load operation (ref. LCV)	Obtained for the newest versions installed
Overall efficiency $\geq 80\%$ (ref. LCV)	Not achieved. Observed interval for overall efficiency 60-78%, primarily depending of return temperature of water in the heating system
Availability $\geq 90\%$	Achieved for most installations
O/M Costs < 10 Euro/MWh _e .	Observed results 13-15 €/MWh
Unit Cost < 800 Euro/kW _e	Observed results: 800-860 /kW
Emission levels < 15 ppm NO _x at 15% O ₂	Achieved at most sites

Development of Basic T 100 Microturbine.

The Turbec T 100 microturbine was a very new product when the OMES project started. This means that some of the very early units had technical faults that were corrected on later units. This affects some of the statistical data, but during the project it could clearly be followed that the later units had improved and more mature characteristics.

Power Efficiency and Overall Efficiency.

The original goals were $\geq 30\%$ net electrical efficiency during full load operation and overall efficiency $\geq 80\%$ (ref. LCV). The measurement results show that the goals for electrical efficiency at full load were achieved for the latest installations (version 3 of the Turbec unit) in the OMES project. Still the overall efficiency stays in the range of 60-78%. This is primarily due to higher water inlet temperature than originally planned for, at many of the demonstration plants. An inlet water temperature less than 50°C seems necessary to achieve the target of 80% total efficiency. All results at "net" conditions including work to raise gas pressure were accounted for. At part load a considerable drop in efficiency was remarked.

Availability $\geq 90\%$.

For the plants in operation this goal was achieved.

Unit Costs.

The OMES project showed that the technology associated with the microturbine is working satisfactorily. The technology is reliable, but work must be done to reduce costs before the microturbine will get a commercial break through in larger volumes. Costs for the T100 unit from factory stay at original planned level of 800-860 €/kW. This indicates that the microturbine will be able to reach its long-term goals, which in the OMES project are set at less than 800 €/kW. Observed costs for the installation of the standard T100 vary considerably, and some extra costs due to obliged OMES measurements have had to be added. The cost variation is of

course to a large extent dependant on variations in site specifications. Further to mention some installations then have to add extra costs for a methanol tank, heating accumulator, absorption chiller, steam mode, noise silencer etc.

A price level of 1000 €/kW (hardware + installation) seems reachable in some years when installers and advisory engineers have become accustomed to this new technology, and installation rules are more clear. A reduction in hardware price from the turbine manufacturers seems possible when high volume production is established.

Maintenance Costs.

The original goal for the OMES project indicated O/M costs less than 10 €/MWh. This goal has so far not been met. The observed O/M costs vary between 13 and 15 €/MWh.

Environment.

The original environmental goals for the OMES project were focusing on NO_x. The measurements showed NO_x values at target level of 15 ppm at 15% O₂

SCIENTIFIC AND TECHNICAL OBJECTIVES

The project includes activities of both R&D and demonstration character. The different applications were developed and validated in relation to optimisation of CHP systems as summarized below.

Cluster Installation of Microturbine CHP Units

A cluster installation of microturbine CHP units is a power generation system consisting of a number of connected CHP systems installed on different sites (close to the consumer) in a limited geographical area and operated by one remote operator. Cluster operation could be interesting regarding especially selling ancillary services to the grid. This could add an important extra income to the operation profit of the involved microturbines. The units are operated in such a way that the total power plant (all units together) is operated as efficiently as possible regarding economy and environment.

Steam Generation

The basic CHP system in this size is designed for heating of water for space heating etc. Many applications have a need for steam. The microturbine offers special advantages in this respect due to the fact that it has all its available heat as hot gases in the exhaust, which is suitable for use in steam production.

Systems for flexible steam production have been analysed and the most promising one was validated in a field test in Ireland.

Use of CO₂ in Greenhouses/Drying

For many industrial processes, the exhaust gas from the gas turbine can be used for drying and for other useful purposes. This project demonstrated the usage of the CO₂ content from the exhaust gases for fertilization in greenhouses.

Cooling

The microturbine offers possibilities for combined cooling/chilling and heating. The cooling is generated with absorption cooling, thus avoiding the use of harmful gases, noise and obtaining long TBO (Time Between Overhauls). Absorption cooling in combination with the microturbine has been installed at Statoil, Norway, and outside the project at the VTT installation in Finland.

Alternative Fuels

The microturbine technology is less sensitive of variation in fuel quality than competing technologies as for example piston engines. Beside that, a microturbine can use a range of fuels like natural gas, LPG, biogas, methanol, light oil etc. Units for natural gas, biogas and methanol were developed and tested in this project.

Innovation

Microturbines for stationary industrial applications are now coming to market after many years of development. Compared to the larger industrial turbines, microturbines are often constructed as radial turbines instead of an axial outline.

To achieve reasonable and competitive shaft efficiency, development work was concentrated on reduction of friction-based losses and the integration of recuperators for preheating the combustion air, thus reducing the fuel consumption. Increasing interest and the implementation of emission regulations have lead to design work to ensure the lowest possible emissions.

Competing Technologies

Microturbine based CHP units are in some applications up against reciprocating engine based units. Generally, the latter still have higher electrical efficiency, approximately 30-34% compared to the registered 30% from the first series of the 100 kW microturbines.

The advantages of using microturbine-based units are expected to be:

- Lower maintenance expenses
- Lower primary emission, especially with regard to NO_x, CO and UHC
- Less space requirements, less vibrations
- Easier multi-fuel possibility
- Higher availability

All these points were measured and demonstrated during the OMES project.

DESCRIPTION OF INSTALLATIONS

Cluster Installations, Køge Denmark

Energi E2 installed 5 T100 micro gas turbine units in a "cluster unit" in the area around Køge, south of Copenhagen, Denmark. All units are CHP units. The units are part of a virtual power plant (cluster plant), monitored, optimised and controlled remotely from a central power plant, Kyndbyværket. See below typical data from two of the units installed in the Cluster arrangement.

Table 3. Plant Description, Torpgården (Cluster units)

Plant	Torpgården Unit 1	Torpgården Unit 2	
Plant owner	Energi E2	Energi E2	
Installed	April 2003	April 2003	
Running hours by April 2004	6,041 hours	6,294 hours	
Fuel	Natural gas	Natural gas	
Function	Heating of houses and	production of hot water	
Power production, kWh (accumulated)	540,000	553,000	
Heat production, kWh (accumulated)	750,000	744,000	
	Factory Test	Factory Test	Precision Test at Site
$\eta_{\text{power gross (excl. pressuration of gas) \%}$	30.35	30.75	32.4
$\eta_{\text{power net \%}}$	28.98	29.41	30.5
$\eta_{\text{total gross (excl. pressuration of gas) \%}$	75.22	76.11	80.7
$\eta_{\text{total net \%}}$	73.85	74.77	78.8
Water temp. out deg. C	90	90	
Water temp. in deg C	50	50	

Copenhagen Airport (2 Units), Denmark

This OMES microturbine installation consists of two natural gas fired Turbec T-100 units. The OMES microturbine CHP installation at Copenhagen Airport premises was installed 2002/2003 after initial analysis of economic viability and possibilities for installation in connection to existing heating stations (gas fired boilers), electrical connection possibilities etc.

The installation cost was as follows: Costs indicated per CHP- unit excl. VAT.

The microturbine unit (Turbec T-100)	80,000 Euro
Building Works	6,500 Euro
Electrical works	7,000 Euro
Gas works	6,000 Euro
Plumbing (water connect/ventilation/exhaust)	17,000 Euro
Meters	6,500 Euro
Other	33,000 Euro
<i>Total (per unit)</i>	<i>156,000 Euro</i>

The operation experiences with the units was quite satisfactory. No major breakdowns and very few unexpected stops occurred until end of the reporting period.

Table 4. Overall Performance Numbers at Copenhagen Airport

	Starts	Op. Hours Total	El Efficiency (LCV) ^{*)}	Total Efficiency (LCV) ^{*)}	Op. Hours versus Total Hours in Period
		(h)	(%)	(%)	(%)
Unit 1	62	5150	29.3	69.4	91.4
Unit 2	70	5147	28.5	72.3	94.6

Electrical efficiency is slightly lower than expected. The total efficiency will be improved if water temperature level could be reduced.

The efficiencies are based on an average calorific value for the gas during the period in question.

Lynge M/R Station, Denmark

This unit was a follow up on a pilot test of an 80 kW unit installed April 1999. The function of the Turbec T100 unit is to produce heat for preheating of natural gas before pressure reduction (from 80 bar to 30 bar). The produced electricity is sold to the local network.

Several energy and emission measurements have been made on this unit. The heat transportation media is a water/glycol solution, which reduces the specific heat to 88% related to pure water, and due to that, a reduction in heat transfer. Related to efficiency this is partly counteracted through the presence of the gas pressure of 6-8 bar, which means that no gas compressor was needed.

Table 5. Plant Description, Lynge

Plant	Lynge M/R Station
Plant owner	Dansk Olie og Naturgas A/S
Running hours by March 31, 2003	22,000
Fuel	Natural gas
Function	Preheating of natural gas before pressure reduction
Power production, GWh	2.1 GWh
Heat production, GWh	2.7 GWh
$\eta_{\text{power net}}$ (as pressuration of gas was needed) %	31.1
$\eta_{\text{total net}}$ (as no pressuration of gas was needed) %	72.1
Water temp. out deg. C	77
Water temp. in deg C	67

Methanol Fired Units at Statoil Main Office, Forus Stavanger and Drammen, Norway

Statoil's objectives for participating in the OMES project were to demonstrate methanol as a fuel and to demonstrate distributed small-scale power units in a commercial environment. The challenge was to introduce methanol to the fuel market in a way, which would enable non-specialists to handle methanol as a commercial fuel. A lot of engineering and authority work was performed by Statoil to achieve this. To avoid any negative focus to this introductory programme, extra safety precautions were introduced.

Two methanol fuelled CHP units were installed in Norway as Statoil's contribution in the OMES project. The units fuelled by methanol produced from natural gas at Statoil's methanol plant at Tjeldbergodden, Norway, demonstrate Statoil's strategy to utilise methanol as a way of distributing natural gas to areas without natural gas supply.

One of the units is installed in the energy central at Statoil's main office complex in Stavanger, Norway, providing electricity, heating and cooling. At this site, a methanol fuelled Turbec T100 coupled to a Broad chiller is installed in the heating central of the main office. The function of the Turbec T100 unit is to produce power to the office complex, to produce heat to the hot water system, and cooling to the chilled water system during the summer season. The cooling system is arranged with a Broad absorption chiller producing approx. 95kW cooling from approx. 165 kW heat delivered from the T100.

The other CHP unit is installed in the boiler room of the residential complex Fjell Borettslag in Drammen, producing heat and power. The main heat production at this site is delivered from two oil-fuelled boilers, one boiler fuelled by wood based bio fuel and one boiler heated by electricity. The heat from the Turbec T100 is delivered to the same hot water heating system. At Fjell, the T100 is producing only a small part of the heat needed as the above-mentioned boilers produce the main heat supply. There is no cooling installation at Fjell.

For both installations, a new methanol fuel supply system was designed and installed by Statoil. For Statoil, it has been important to gain experience with methanol as fuel and information on plant efficiency, reliability and availability, emissions and economy.

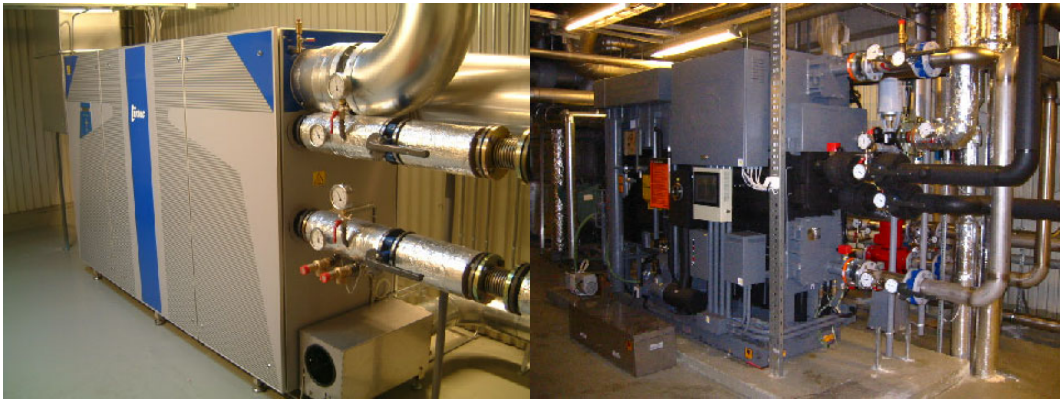

Figure 1. The Microturbine and Chiller Installation at Statoil, Stavanger

The conclusions from the T100 test with methanol are that the microturbine is well suited for CHP combined with cooling. The efficiency loss is less when the T100 is operating on liquid fuel compared to gas, as the pumping of liquid requires less power. However, careful design of the fuel system has to be made to avoid problems with components from synthetic materials coming into contact with the fuel.

The T100 should have the ability to operate independently of grid power, thereby adding value to this system as distributed power and to be used both as the primary power source and UPS.

Mariestad Sewage Treatment Plant, Sweden

A T100 prototype was installed late 2001/beginning 2002 at the Mariestad sewage treatment plant. It was designed to run on the raw biogas from the sewage treatment plant. The turbine should produce heat and electricity for internal use at the plant, replacing an older oil fired boiler.

Promised gas production was initially exceeding 800 Nm³/day but actual production was less than 200-250 Nm³/day, which resulted in only few running hours for this installation. With methane content of 55-60%, this equals a gas input of 50-60 kW, i.e. very much

below the T100 rated gas input of 333 kW.

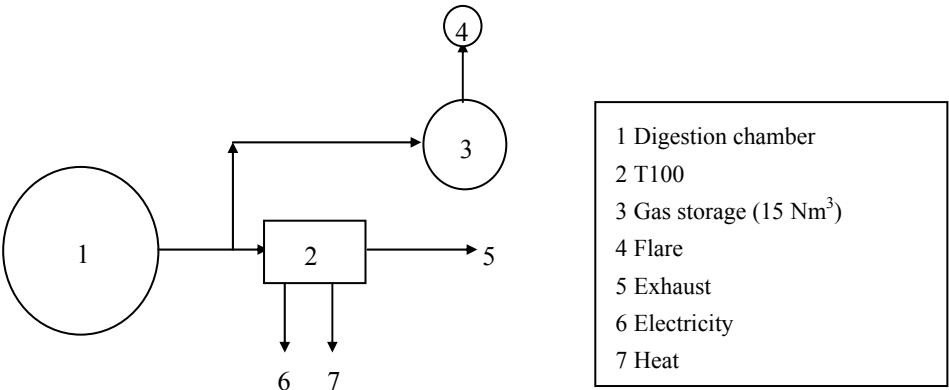

Figure 2. Schematic Installation of the Mariestad Site

Initially, it was decided to go ahead with the 200-250 Nm³/day and run the turbine on part load (50-80%). Unfortunately, the gas production did not improve after the tuning of the digestion chamber. It was only possible to run the turbine on 20-25 kW_e.

The first problem was moisture in the gas and it was solved with an additional water separator. Generally spoken, biogas production is typically a varying process, resulting in an uneven gas flow. For future projects it is therefore suggested that a typical biogas/CHP site is done in the following way:

The nominal biogas flow should at least be 20-30% higher than the needs of the T100 i.e. the nominal gas flow should exceed 400 kW. It is *not recommended* to install the T100 at biogas plants/landfills with lower nominal gas production than 350 kW. The T100 should be running as base load at 100% load for all hours, utilizing as much gas as possible.

To utilize the varying gas flow, it is suggested that a heat-producing boiler is installed and any excess gas is burnt off in the boiler and used for heat production. The boiler should be fitted with a modulating burner that can handle varying gas flows. Despite the poor number of running hours the final conclusions from the Mariestad site are that microturbines are expected to have a bright-looking future for biogas applications.

Klitte Greenhouse, Sweden

It is well documented that CO₂ fertilization in greenhouses increases the growth rate with approximately 15-30%. Outside air contains approximately 350 ppm CO₂ but by increasing the rate up to 700-1200 ppm, a significant growth increase has been observed in numerous studies. If no additional CO₂ is supplied, the level inside the greenhouse can drop below the outdoor air level because of the CO₂ consumption of the crops and this causes a lower growth rate.

The flue gases from a conventional gas engine can be lead to the greenhouse by a pipe system. The gas engine is also used for cogeneration. Flue gas cleaning (SCR catalyst system) and high dilution of the flue gases will be necessary.

During recent years, the development of small gas turbines (microturbines) with low emissions and high efficiency has enabled microturbine based CO₂ fertilization. Gas turbines have considerably lower NO_x, CO and UHC emissions compared to modern gas engines and are therefore highly suitable for CO₂ fertilization.

The unit was installed in an existing boiler room. A new CO₂ distribution system for the flue gases from the turbine was installed. The levels of UHC, CO NO, NO₂ and CO₂ inside the greenhouse were proven to be well below hygienic limits.

Table 6. Exhaust Gas and Greenhouse Air Concentrations of Different Species

Component	Flue Gas Concentration (15% O₂)	Greenhouse Air Concentration
NO	12 ppm	100 ppb
NO ₂	2 ppm	20 ppb
NO _x	14 ppm	-
CO	ND	1 ppm
CO ₂	1,5%	600-1200 ppm
UHC	ND	ND

The T100 is well suited for CO₂ fertilization. From an energy efficiency point of view, CHP and CO₂ fertilization is highly efficient, as approximately 100% of the energy (LHV) is utilized, and the only significant loss is the power required for the gas booster (< 5 kW) and ventilation losses (5-10 kW).

Kävlinge

This unit was installed as part of a heating system including two boilers. The microturbine CHP unit supplements the heat provided by the boilers during periods when demand is high. When demand is low, it provides all of the heat for the complex. The electricity not used at the installation site is sold back to the electrical utility and supplied to the building complex through the grid.

One precision test was carried out for the prototype unit and the results can be found below.

Table 7. Results for the Precisions Measurements from Kävlinge

	50% (54 kW)	75% (74 kW)	100% (99 kW)
Gross electrical efficiency	26%	29%	31,3%
Net electrical efficiency	24%	27%	29,6%
Total net efficiency	64%	70%	75,4%

The electrical efficiency ranges from 25-30%, but is clearly higher after the prototype and piston compressor was replaced. The average for the prototype period was 28,4% and for the period after 2002-02-27 the efficiency was 29,4%.

Table 8. Electrical Efficiency for the Kävlinge Unit

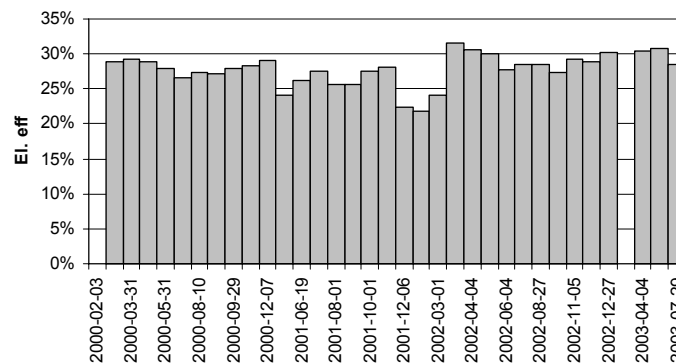
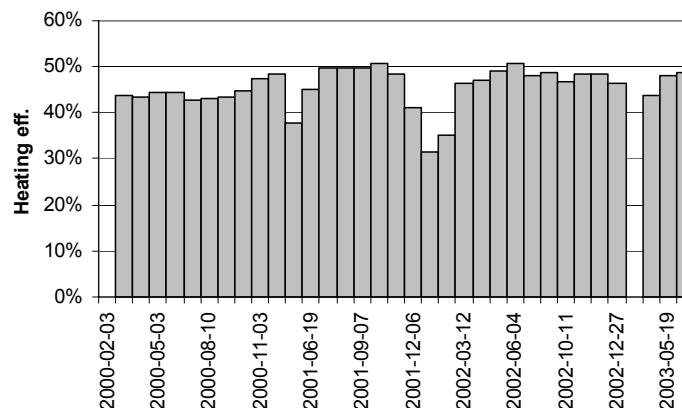

Table 9. Heating Efficiency for the Kävlinge Unit



The heating efficiency ranges from 40-50% during almost the entire period and the average for the prototype period was 46.4% and for the period after 2002-02-27 the efficiency

was 47.2%. Quite clearly, the prototype unit was performing well in terms of heating efficiency.

VTT, Finland

The Turbec T100 unit was installed at VTT Processes in November 2002. The unit is producing electricity and heat to the building of VTT Processes at Otaniemi, Espoo. The unit is connected to both electric and district heating network, and late in the OMES project it was supplied with an absorption cooling unit. T100 unit had by March 2003 operated about 9400 hours. There had been 179 start operations during this period.

Table 10. Plant Description VTT

Plant	VTT
Plant owner	VTT
Installed	November 2002
Running hours by 31 st March 2004	9387
Fuel	Natural gas
Function	CHP (Combined Heat and Power)
Power production kWh	950 250
Heat production kWh	970 100
$\eta_{\text{power net}}$ %	29.7
η_{heat} %	30.3
$\eta_{\text{total net}}$ %	60.0
Water temp. out °C	111
Water temp. in °C	93
Cooling capacity (national project with own funding).	100 kW (Thermax LiBr absorption chiller – chilled water temperature 7-10°C)
Steam capacity	-

The emissions were very low when operating at full load 115 kW_e and 100 kW_e, but dramatically increased when the power decreased. Only the NO_x emissions are quite low independently of the power. The high emissions in lower loads come from the poor combustion. If high efficiency and low emissions are requested, the turbine should only operate close to full load.

Table 11. Emission Measurements, VTT

Measured	Unit	115 kW _e	100 kW _e	86.3 kW _e	75 kW _e	57.5 kW _e	50 kW _e
CO dry 15% O ₂	Ppm	3.3	0	393	568	1074	1083
HC wet 15% O ₂	Ppm	3.6	0.1	227	389	1164	1128
NO wet 15% O ₂	Ppm	10.2	9.6	7.3	9.1	10.5	12
NO _x wet 15% O ₂	Ppm	11.4	10.4	9.9	11.3	13.9	15
CO ₂ dry 15% O ₂	%	3.4	3.3	3.2	3.2	3.2	3
O ₂ dry	%	18.05	18.09	18.29	18.34	18.61	18.64

Hamburg, Business Centre, Germany

This unit was installed in September/October 2002, in a container in close connection to an office building and delivers heat and electricity to the customer.

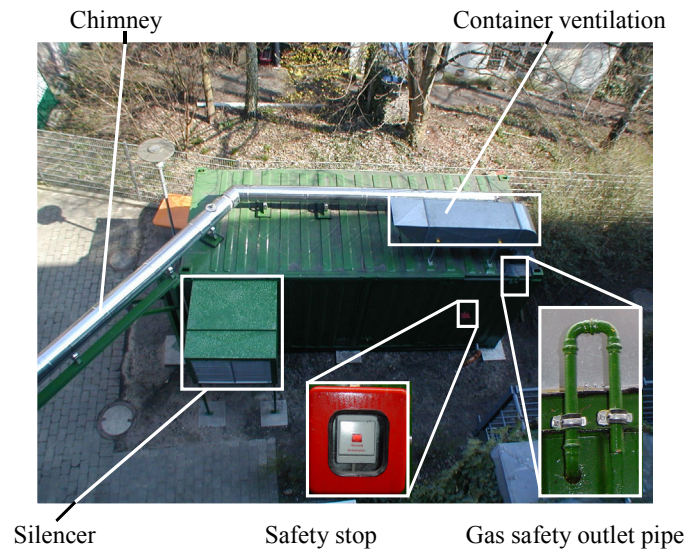

Figure 3. The Microturbine housing in a container at Hamburg

The site Harburg Channel in Hamburg was one of several alternatives. The reason for this choice was a better economy in Germany compared with Sweden and that Vattenfall has a subsidiary in Hamburg. Important factors in evaluation of the site have been electricity price, gas price, and yearly operation and heat consumption.

The main components in the container are the Turbec T-100, the Copeland gas compressor, the coarse filter and the air inlet tube. In the container there are pipes and fan for ventilation, a one hundred litre expansion vessel and pipes for connection of gas, water, exhaust gas and others. In the container is a measuring box with two computers for sampling and sending information installed.

There are some special solutions due to the installation in the container.

- Silencer of the air inlet
- Noise reduction of the container
- Ventilation of the container
- Safety stop from outside
- Gas safety outlet pipe
- Chimney

The container is covered inside on the walls and on the roof with mineral wools and perforated sheets to reduce noise. The doors are tightening with sound absorbing material. In the container some noise sources are partly covered with sound absorbing material.

The maximum allowed noise level is 45 db(A). The unit is placed very close (in a distance of ½ meter) to the neighbour. The container therefore was insulated with noise reduction

material and equipped with a silencer for the air inlet. The noise was measured to be 43 db(A).

Irish Coop Society, Limerick, Ireland (steam site)

This demonstration plant was established at an industry in Limerick on western Ireland. The T100 is part of a steam boiler/T100 system that produces heat and electricity to the industry. The T100/boiler system produces steam and electricity to the industry during daytime when electricity and peak tariffs are high. The Irish Coop Society (ICS) in Limerick makes corrugated cardboard paper and has an all-year demand for steam. The T100 unit is used for steam and warm air production.

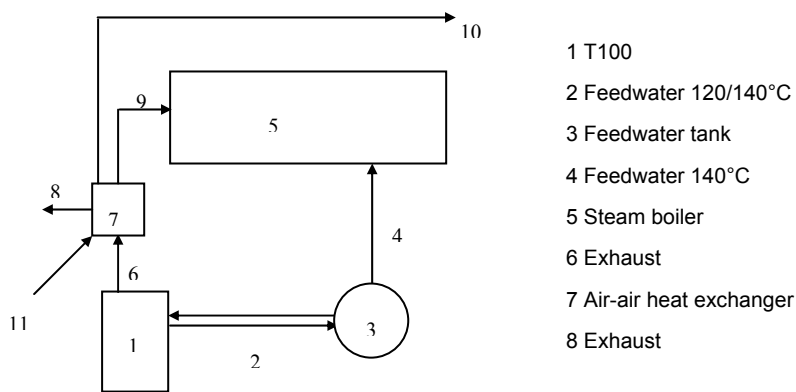

Figure 4. Schematic of the ICS Installation

The settings are (approximate):

Pre-heated combustion air: 45°C, 7,500 Nm³/h
 Shop hot air: 63-67°C, 2,200 Nm³/h

Altogether the installation was rather complex and resulted in the “octopus looking” air-air heat exchanger that supplies the burner and the shop with hot air. When leaving the air-air heat exchanger, the ventilation air from the unit is used to heat the shop while pre-heated air is used in the burner of the steam boiler. The final exhaust goes through the wall and is released as for any CHP installation. If the air fan is not running (steam boiler is not running) there is a possibility to bypass the fan.

The electrical efficiency is in line with what could be expected but the heating (hot water) efficiency was much lower than expected. This is due to the fact that the ΔT of the feed water is only 5-7°C, and it would be required to triple the flow to reach the desired output, but due to the risk of cavitations in the high-pressure pump this is not a solution.

When the air-air heat exchanger was enlarged due to the initial high-pressure drop, it resulted in a slight over-dimensioned heat exchanger and this turned out to be quite fortunate when the hot water output was so low. Much of the losses could be reclaimed in the air-air heat exchanger and this resulted in an overall very acceptable efficiency.

St John of God Hospital (SJOG), Dublin, Ireland

In 2002 a T100 was installed at St John of God Hospital in Dublin, Ireland. All of the electricity and heat is used in the hospital. In addition to the hot water supplied from the T100, a secondary heat exchanger is installed to produce additional heat. This heat is used for pre-heating the warm tap water.

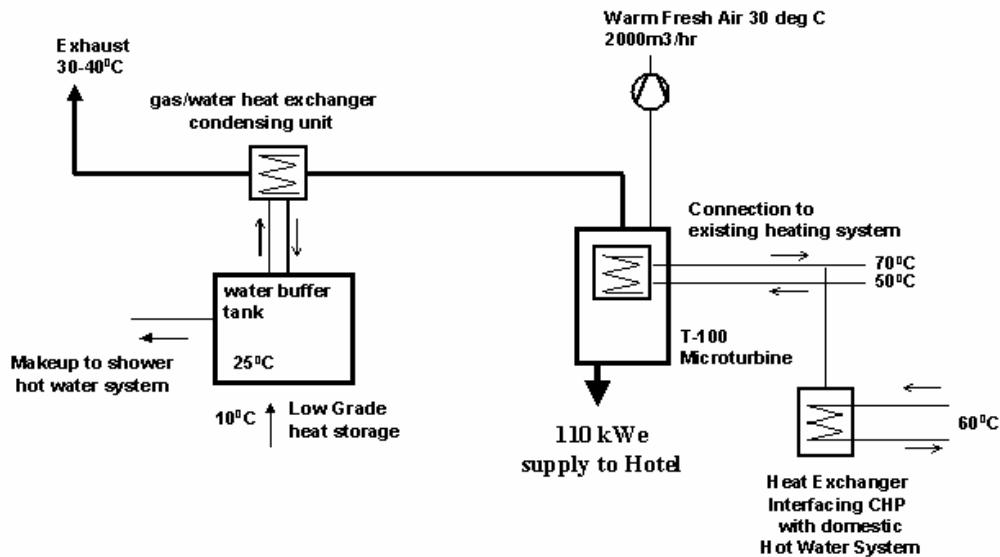

Figure 5. Schematic Installation of the SJOG Site

Installation Costs:

Turbine:	80,000 €
Installation costs:	63,950 €
OMES metering equipment:	13,500 €
Total installation:	157,450 €

The installation cost was increased with approx. 20-30,000 €, due to participation in the OMES project, mainly because of the late inclusion of the SJOG unit in the OMES project.

The average electricity price in 2003 was: 11 € cent/kWh

Gas price in 2003 was: 1.92 €cent/kWh

The unit is set to run 15.5 hours per day, 365 days per year which results in 5660 running hours per year.

Produced electricity: $5660 \times 115 \times 0.11 = €71,559$

Produced heat: $5660 \times 150 \times 0.0192 \times 1.1 = €17,931$

Bought gas: $5660 \times 393 \times 0.0192 = €42,708$

Maintenance is approximately = €2,000 per year

Which gives a pay-back period of 3.5 years.

SAS Radisson Limerick, Limerick, Ireland

Early 2003 a T100 was installed at the SAS Radisson Hotel in Limerick on Eastern Ireland. All of the electricity and heat is used at the hotel.

This site is a 154 bedroom full-service hotel, with 10,000 square meters of conference facilities in addition to a Leisure centre.

The T100 provides heat and electricity to the hotel during daytime when electricity and peak tariffs are high. Expected annual running hours are 4-5,000 hrs with an approximately 2-300 starts per year. Under the original heating infrastructure at the Limerick Radisson there are two separate heating systems. The central heating system operated by two 600 kW boilers is used to provide central heating for the leisure centre and the hotel. The second heating system, the domestic hot water system used to heat water for showers and the kitchen, is separately heated by three direct gas-fired heater units. Under the CHP configuration, the 185kW heat produced by the CHP is supplied to these two primary heat consumption centres as follows:

- Central heating hot water provided to the hotel central heating system from the CHP unit.
- Heat transferred to the domestic hot water system from the CHP via a heat exchanger interfacing the central heating system with three new insulated DHW storage containers.

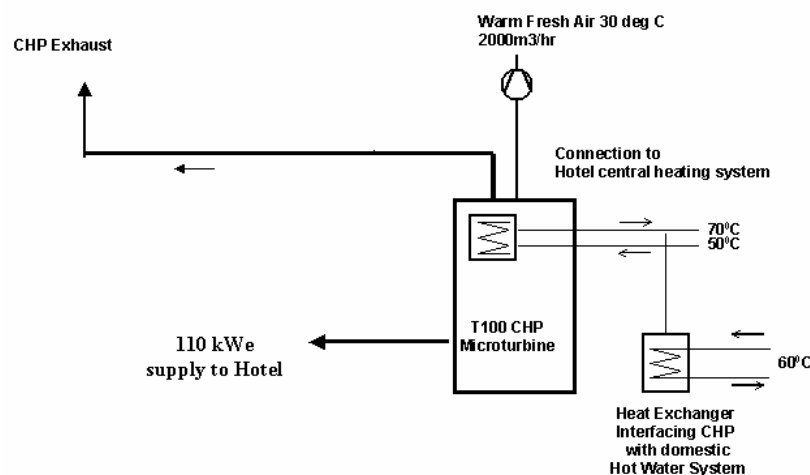

Figure 6. Schematic Installation of the SAS Radisson Site

The building work was substantial due to very limited space to install a T100. The existing boiler room was packed with boilers, calorifiers and piping and it was decided to place the T-100 outdoors, on top of the boiler room.

MARKET POTENTIAL EVALUATION IN EU

As a part of the OMES project a market potential evaluation for the EU countries should be made.

This report aims at describing the market potential in Europe for micro gas turbines (MGTs). This investigation covers combined heat and power (CHP) based on MGTs in the power range between 20 and 200 kW. The investigation primarily evaluates the market potential from a technological point of view and utilizes to some extent results from other investigations on market potential.

The investigation includes identification of which typical heat demands are satisfied with CHP based on a MGT.

The largest market potential for MGTs is CHP-installations in hotels, schools, hospitals, office buildings, apartment houses, sports centres, swimming baths, super markets and shopping centres (combined heat, power and cooling (CHPC) for satisfying heating and cooling demands), greenhouses (CHP and CO₂-fertilization), industrial laundries, sewage treatment plants, small and medium sized enterprises (SME)'s with a certain profile of heat demand or some special process integrated industrial applications.

Integration of an MGT in some industrial processes can lead to very high-energy efficiency (i.e. direct drying or with supplementary firing, also giving very high marginal electrical efficiency, or when exhaust gas is used directly for heating and CO₂-fertilization in greenhouses). In such applications, the economics can be attractive given the present and predominantly levels in cost for gas and electricity. However, the market potential in such "special applications" is expected to be rather limited.

Areas with no or poor supply of electricity or where the electricity grid needs reinforcement are very potential markets.

Areas with a long heating season and dense population are also potential markets. However, if district heating already is implemented, then district heating based on relatively large CHP plants with high electrical efficiencies are most likely both technically and economically more competitive.

In order to pay back within reasonable time, an MGT for CHP has to operate intensively. Three thousand hours of full-load operation per year is considered as absolute minimum. This fact sets up restrictions on heat demands in terms of base load and heat storage capacity and limits the number of locations suited.

However, the present levels in specific cost for installation and cost related to overhaul & maintenance for this rather new and still maturing technology have to be reduced and/or the predominantly gap between cost of electricity and gas has to be increased, to make it economically attractive substituting existing energy systems with CHP based on microturbine units.

For the time being, support for promoting the further development and reduce installed cost of this new technology is necessary.

As the energy market in EU is being liberalized, costs of electricity and fuel can to some extent be expected levelled. However this may take long time due to bottlenecks especially in the electricity grid.

The market potential in EU has been estimated roughly based on above considerations and limitations. *The total technically market potential in EU-15 for CHP based on MGTs in the commercial, industrial and residential sectors have been estimated to almost 950 thousands units.* The average unit size is estimated to 60 kWe amounting to a total installed capacity of 57 GWe.

In the industrial sector (not focusing CHP production), the main market potential is expected to be integrated solutions like CHPC, direct drive applications and destruction of VOCs (Volatile Organic Compounds). However, such integrated applications need to be further developed, technically matured and produced in large numbers before a commercial break-through can be expected.

RESULTS OVERVIEW

Table 12. Overview for Major Results from the OMES Project

No. of Installations	Site	Customer Price - Microturbine Unit X 1000 €	Installation incl. Extra Costs x 1000 € (per unit)	Running Hours per Microturbine April 2004	Observed Net Efficiency. (Power/Total) At Site and/or at Turbec	Remarks
2	Cph Airport	80	76	5200	(28.9/70.8) **)	Several occasions with more than 2000 hours without stops
	Apartment houses, Køge					
2	Torpgården	81.5	91.75	6150	(30.5/78.8) ***)	2 units for one heat accumulator (20 m ³)
1	Ørnesædet	81.5	116.5	1225	(31.5/71.4) ***)	Few running hours due to noise complains. Must not operate in night hours
1	Hastrupvænge	81.5	131.5	7200	(30.2/76.7) **)	Heat accumulator of 20 m ³ - silencer at chimney
1	Tigervej	81.5	162.2	4700	(30.1/74.7) **)	Heat accumulator of 20 m ³
1	M/R station, Lyngø	80	100	22.000	(31.1/72.1) ***)	Started as Turbec prototype april 1999
1	Statoil, Stavanger	80	> 300 *)	3100	(30/69) ***)	Methanol and chilling
1	Fjell Borettslag	80	> 250 *)	2400	(30/61) ***)	Methanol
1	Mariestads Avl. Rening.	80	> 100	200	(not measured)	Very few running hours due to lack of biogas
1	Klitte & Lundh (Green House)	80	68	2200	(not measured)	Well suited for CO ₂ fertilization at max load - not at part load.
1	School at Kävlinge	installation not a part of the OMES project	installation not a part of the OMES project	12000	(29.6/75.4) **)	The very first commercial Turbec installation
1	VTT	86	87	9400	(31.4/61.1) ***)	Cooling installation not included
1	Buss. Centre, Hamburg	82	96.8	2500	(29/63) **)	Container solution.
1	Industry Limerick	80	110	1000	(30.2/73.6) **)	Steam production
1	St. John of God Hosp. Dublin	80	80	6730	(25-30/50-75) **) (diffuser problems)	Leaking diffuser
1	Ht. SAS Radisson, Limerick	80	64	6300	(29.8/65) **)	Availability 95-98%

*) Special installation considerations due to methanol tank etc.

***) Test results from Turbec

****) Precision test at site

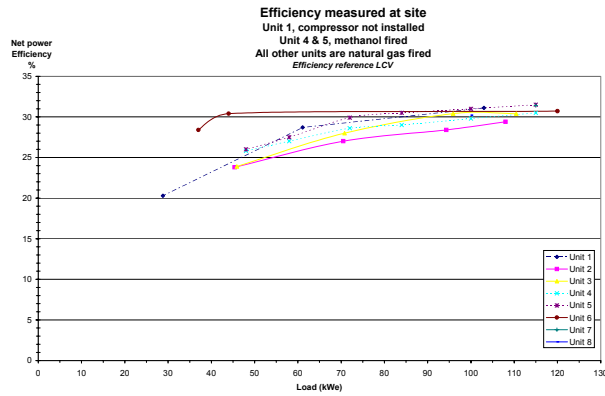

Figure 7. Power Efficiency Measurements on Site

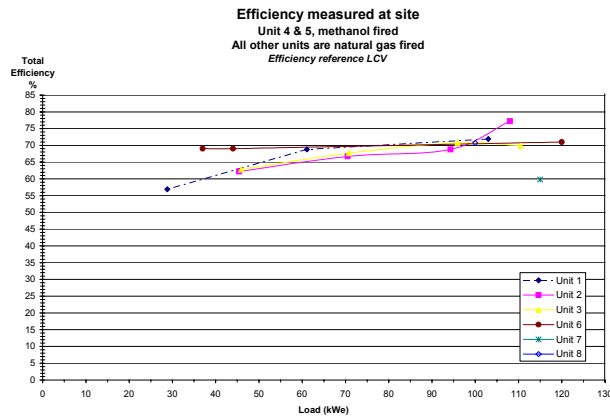

Figure 8. Electric Efficiency Measured at 7 Sites

Environmental Measurement

At most of the demo plants measurements of emissions for NO_x, CO and UHC have been made, ref. Figure 9 - Figure 11. For almost all sites the environmental goals:

NO_x < 15 ppm at 15% O₂

CO < 15 ppm at 15% O₂

UHC < 10 ppm at 15% O₂

were achieved at full load. At part load (75% load or lower) this picture changed, and especially the content of CO and UHC rose dramatically. This picture was observed at all gas fired demo sites where environmental observations were made.

For the methanol-fired plants this picture was almost the same, still the UHC emission demands could also be meet at low load.

NOx Emission,

Precision measurements at site.
Unit 1-5 are natural gas fired
Unit 6 and 7 are methanol fired

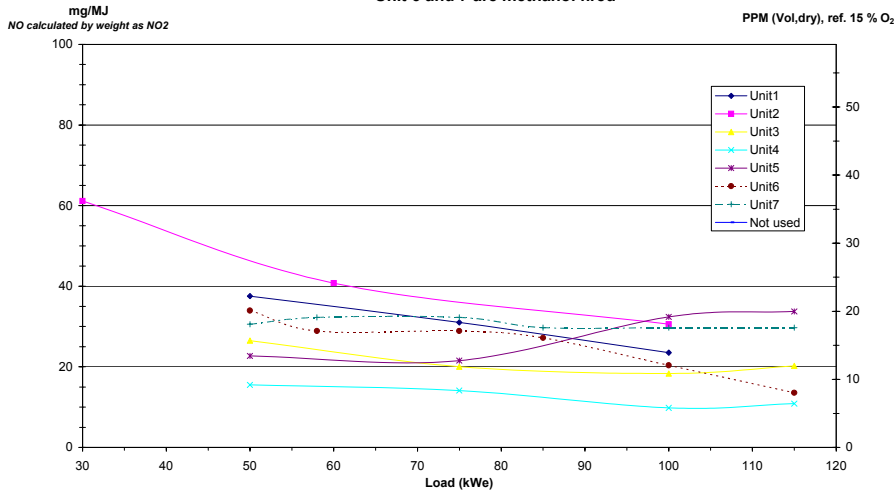

Figure 9. NO_x emission

UHC Emission,

Precision measurements at site,
Unit 1-5 are natural gas fired
Unit 6 and 7 are methanol fired

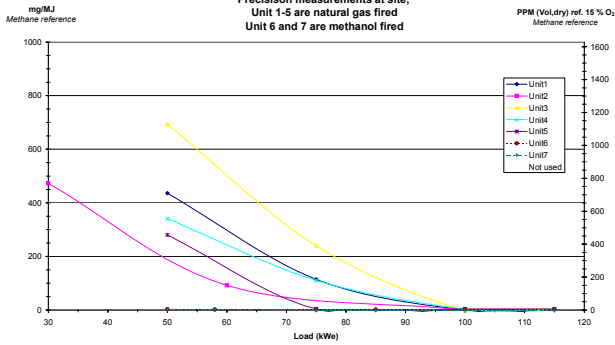

Figure 10. UHC emission

CO Emission,

Precision measurements at site,
Unit 1-5 are natural gas fired
Unit 6 and 7 are methanol fired

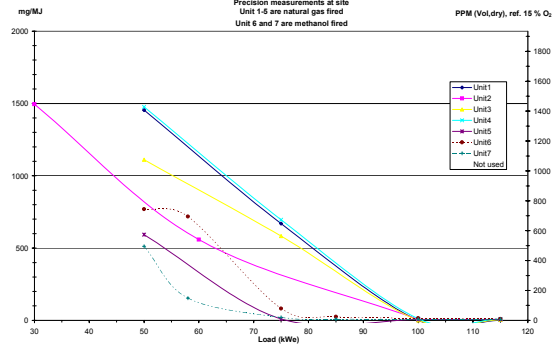

Figure 11. CO emission

REFERENCES

1. H.J. Rasmusen, Optimised microturbine energy systems, EC ENERGY Contract NNE5/20128/1999, 2001.
2. Mini- and micro-gas turbines for combined heat and power. P.A. Pilavachi, Applied Thermal Engineering (2002) p. 2003 - 2014

